



**N.B.** For the correct choice of the gearmotor, please refer to the tables on page 118. Refer to AM series page 12 for motor revs under load. On request, motor may be supplied with electromagnetic brake at 230 Vac. marked with letter KA (PAEKA). or at 24 Vdc. marked with letter KB (PAEKB). see specifications on page 120.

**N.B.** Para una selección correcta del motorreductor se aconseja ajustarse a las tablas presentadas en la página 118. Para las revoluciones motor bajo carga hágase referencia a la serie AM pág. 12. A petición es posible proporcionar el motor con freno electromagnético alimentado con 230 Vca. que se distingue por la letra KA (PAEKA) ó 24Vdc. que se distingue por las letras KB (PAEKB). ver características en la pág. 120.

## COAXIAL GEARED MOTOR WITH PLANETARY REDUCTION GEAR

**MOTOR:** Asynchronous single or three phase with 2 or 4 poles. totally enclosed with external ventilation. Thermal safety cutout on single phase models. Class F windings. IP65 protection according to CEI EN 60529.

**GEAR UNIT:** First stage die-cast aluminum housing, second stage steel. Case-hardened gearing with shafts rotating on roller bearings. Lubricated with synthetic oil. High temperature oil seals. 13 gear ratios (i) from 48.7 to 1770.9. Rated torque 796.5 in-lbs. Versions B3 or B5.

## MOTORREDUCTOR COAXIAL DE ENGRANAJES CON REDUCTOR EPICICLOIDAL

**MOTOR:** *asíncrono monofásico o trifásico de 2 ó 4 polos. en forma cerrada con ventilación externa. Protector térmico de seguridad en el tipo monofásico. Aislamiento clase F. Protección IP 65 según normas CEI EN 60529.*

**REDUCTOR:** *Primera etapa con carcasa de aluminio inyectado a presión, segunda etapa de acero. Engranajes templados y endurecidos con correspondientes ejes que giran sobre cojinetes de rodillos. Lubricación con aceite especial de larga duración. Retenes para le estanqueidad de goma especial para altas temperaturas. Las relaciones de reducción disponibles (i) son 13. de 48.7 a 1770.9. Par nominal 796.5 in-lbs. Versión B3 ó B5.*



Type Tipo	Ratio Relación	Delivered power Potencia entregada	Input r.p.m. no-load Revoluciones entrada sin carga	Output r.p.m. no-load Revoluciones salida sin carga	Rated torque Par nominal	Voltage Tensión	Current Intensidad	Capacitor Condensador
	i	W	rpm	rpm	in-lbs	Vac - 60 Hz	A	µF
PAE 180M2	48.7	1/8	3360	68.8	79.6	115 1Ø	1.63	20
PAE 240M3	48.7	1/5	3360	68.8	163.7	115 1Ø	2.47	32
PAE 130M2	48.7	1/18	1680	34.2	71.7	115 1Ø	1.08	12.5
PAE 165M3	48.7	1/14	1680	34.2	115	115 1Ø	1.28	16
PAE 260M2T	48.7	1/8	3360	68.8	79.6	230 3Ø	0.6	-
PAE 440M3T	48.7	1/4	3360	68.8	223.0	230 3Ø	1.08	-
PAE 140M2T	48.7	1/16	1680	34.2	95.6	230 3Ø	0.4	-
PAE 230M3T	48.7	1/10	1680	34.2	175.2	230 3Ø	0.7	-
PAE 180M2	67	1/8	3360	49.8	111.5	115 1Ø	1.63	20
PAE 240M3	67	1/5	3360	49.8	223.0	115 1Ø	2.47	32
PAE 130M2	67	1/18	1680	24.8	95.6	115 1Ø	1.08	12.5
PAE 165M3	67	1/14	1680	24.8	159.3	115 1Ø	1.28	16
PAE 260M2T	67	1/8	3360	49.8	111.5	230 3Ø	0.6	-
PAE 440M3T	67	1/4	3360	49.8	307.1	230 3Ø	1.08	-
PAE 140M2T	67	1/16	1680	24.8	135.4	230 3Ø	0.4	-
PAE 230M3T	67	1/10	1680	24.8	243.4	230 3Ø	0.7	-
PAE 180M2	83.6	1/8	3360	39.6	139.8	115 1Ø	1.63	20
PAE 240M3	83.6	1/5	3360	39.6	178.8	115 1Ø	2.47	32
PAE 130M2	83.6	1/18	1680	19.8	123.9	115 1Ø	1.08	12.5
PAE 165M3	83.6	1/14	1680	19.8	196.6	115 1Ø	1.28	16
PAE 260M2T	83.6	1/8	3360	39.6	139.8	230 3Ø	0.6	-
PAE 440M3T	83.6	1/4	3360	39.6	386.7	230 3Ø	1.08	-
PAE 140M2T	83.6	1/16	1680	19.8	159.3	230 3Ø	0.4	-
PAE 230M3T	83.6	1/10	1680	19.8	299.1	230 3Ø	0.7	-
PAE180M2	119.7	1/8	3360	27.6	199.1	115 1Ø	1.63	20
PAE 240M3	119.7	1/5	3360	27.6	399.1	115 1Ø	2.47	32
PAE130M2	119.7	1/18	1680	13.8	180.0	115 1Ø	1.08	12.5
PAE165M3	119.7	1/14	1680	13.8	278.8	115 1Ø	1.28	16
PAE 260M2T	119.7	1/8	3360	27.6	199.1	230 3Ø	0.6	-
PAE 440M3T	119.7	1/4	3360	27.6	550.5	230 3Ø	1.08	-
PAE140M2T	119.7	1/16	1680	13.8	230.0	230 3Ø	0.4	-
PAE 230M3T	119.7	1/10	1680	13.8	431.0	230 3Ø	0.7	-
PAE180M2	164.6	1/8	3360	20.4	275.2	115 1Ø	1.63	20
PAE 240M3	164.6	1/5	3360	20.4	550.5	115 1Ø	2.47	32
PAE130M2	164.6	1/18	1680	10.2	246.9	115 1Ø	1.08	12.5
PAE165M3	164.6	1/14	1680	10.2	386.7	115 1Ø	1.28	16
PAE 260M2T	164.6	1/8	3360	20.4	275.2	230 3Ø	0.6	-
PAE 440M3T	164.6	1/4	3360	20.4	758.4	230 3Ø	1.08	-
PAE140M2T	164.6	1/16	1680	10.2	319.5	230 3Ø	0.4	-
PAE 230M3T	164.6	1/10	1680	10.2	594.7	230 3Ø	0.7	-



# PAE

Type Tipo	Ratio Relación	Delivered power Potencia entregada	Input r.p.m. no-load Revoluciones entrada sin carga	Output r.p.m. no-load Revoluciones salida sin carga	Rated torque Par nominal	Voltage Tensión	Current Intensidad	Capacitor Condensador
	i	HP	rpm	rpm	in-lbs	Vac - 60 Hz	A	µF
PAE180M2	205.2	1/8	3360	16.3	343.4	115 1Ø	1.63	20
PAE 240M3	205.2	1/5	3360	16.3	690.3	115 1Ø	2.47	32
PAE130M2	205.2	1/18	1680	8.2	307.0	115 1Ø	1.08	12.5
PAE165M3	205.2	1/14	1680	8.2	483.2	115 1Ø	1.28	16
PAE 260M2T	205.2	1/8	3360	16.3	343.4	230 3Ø	0.6	-
PAE 440M3T	205.2	1/4	3360	16.3	*796.5	230 3Ø	1.08	-
PAE140M2T	205.2	1/16	1680	8.2	394.7	230 3Ø	0.4	-
PAE 230M3T	205.2	1/10	1680	8.2	742.5	230 3Ø	0.7	-
PAE180M2	293.9	1/8	3360	11.4	491.1	115 1Ø	1.63	20
PAE 240M3	293.9	1/5	3360	11.4	*796.5	115 1Ø	2.47	32
PAE130M2	293.9	1/18	1680	5.6	442.5	115 1Ø	1.08	12.5
PAE165M3	293.9	1/14	1680	5.6	690.3	115 1Ø	1.28	16
PAE 260M2T	293.9	1/8	3360	11.4	491.1	230 3Ø	0.6	-
PAE 440M3T	293.9	1/4	3360	11.4	*796.5	230 3Ø	1.08	-
PAE 140M2T	293.9	1/16	1680	5.6	566.4	230 3Ø	0.4	-
PAE 230M3T	293.9	1/10	1680	5.6	*796.5	230 3Ø	0.7	-
PAE180M2	404.1	1/8	3360	8.3	674.4	115 1Ø	1.63	20
PAE 240M3	404.1	1/5	3360	8.3	*796.5	115 1Ø	2.47	32
PAE130M2	404.1	1/18	1680	4.1	610.7	115 1Ø	1.08	12.5
PAE165M3	404.1	1/14	1680	4.1	*796.5	115 1Ø	1.28	16
PAE 260M2T	404.1	1/8	3360	8.3	674.4	230 3Ø	0.6	-
PAE 440M3T	404.1	1/4	3360	8.3	*796.5	230 3Ø	1.08	-
PAE140M2T	404.1	1/16	1680	4.1	782.3	230 3Ø	0.4	-
PAE 230M3T	404.1	1/10	1680	4.1	*796.5	230 3Ø	0.7	-
PAE180M2	503.8	1/8	3360	6.6	*796.5	115 1Ø	1.63	20
PAE130M2	503.8	1/18	1680	3.2	762.0	115 1Ø	2.47	12.5
PAE165M3	503.8	1/14	1680	3.2	*796.5	115 1Ø	1.08	16
PAE 260M2T	503.8	1/8	3360	6.66	*796.5	230 3Ø	0.6	-
PAE140M2T	503.8	1/16	1680	3.2	*796.5	230 3Ø	0.4	-
PAE180M2	721.4	1/8	3360	4.6	*796.5	115 1Ø	1.63	20
PAE130M2	721.4	1/18	1680	2.3	*796.5	115 1Ø	2.47	12.5
PAE 260M2T	721.4	1/8	3360	4.6	*796.5	230 3Ø	0.6	-
PAE140M2T	721.4	1/16	1680	2.3	*796.5	230 3Ø	0.4	-
PAE180M2	992	1/8	3360	3.4	*796.5	115 1Ø	1.63	20
PAE130M2	992	1/18	1680	1.7	*796.5	115 1Ø	2.47	12.5
PAE 260M2T	992	1/8	3360	3.4	*796.5	230 3Ø	0.6	-
PAE140M2T	992	1/16	1680	1.7	*796.5	230 3Ø	0.4	-
PAE 180M2	1236.8	1/8	3360	2.6	*796.5	115 1Ø	1.63	20
PAE130M2	1236.8	1/18	1680	1.3	*796.5	115 1Ø	2.47	12.5
PAE 260M2T	1236.8	1/8	3360	2.6	*796.5	230 3Ø	0.6	-
PAE140M2T	1236.8	1/16	1680	1.3	*796.5	230 3Ø	0.4	-



Type Tipo	Ratio Relación	Delivered power Potencia entregada	Input r.p.m. no-load Revoluciones entrada sin carga	Output r.p.m. no-load Revoluciones salida sin carga	Rated torque Par nominal	Voltage Tensión	Current Intensidad	Capacitor Condensador
	i	HP	rpm	rpm	in-lbs	Vac - 60 Hz	A	µF
PAE180M2	1770.9	1/8	3360	1.8	*796.5	115 1Ø	1.63	20
PAE130M2	1770.9	1/18	1680	0.8	*796.5	115 1Ø	2.47	12.5
PAE 260M2T	1770.9	1/8	3360	1.8	*796.5	230 3Ø	0.6	-
PAE140M2T	1770.9	1/16	1680	0.8	*796.5	230 3Ø	0.4	-

(\*) - Under no circumstances should the torque values marked with an asterisk be exceeded. With the higher gear ratios the motor power is considerably higher than the capacity of the gear unit.

(\*) - Los valores referentes al par marcados con el asterisco, no se deben en absoluto superar, ya que, con las altas relaciones, la potencia del motor es notablemente mayor que la capacidad del reductor.

Also available in 230 Vac single phase input.  
Also available in 460 Vac three phase input.  
Note - 230 Vac three phase suitable at 208 Vac.

Disponible también con entrada monofásica de 230 Vca.  
Disponible también con entrada trifásica de 460 Vca.  
Nota - 230 Vca trifásica adecuada para 208 Vca.

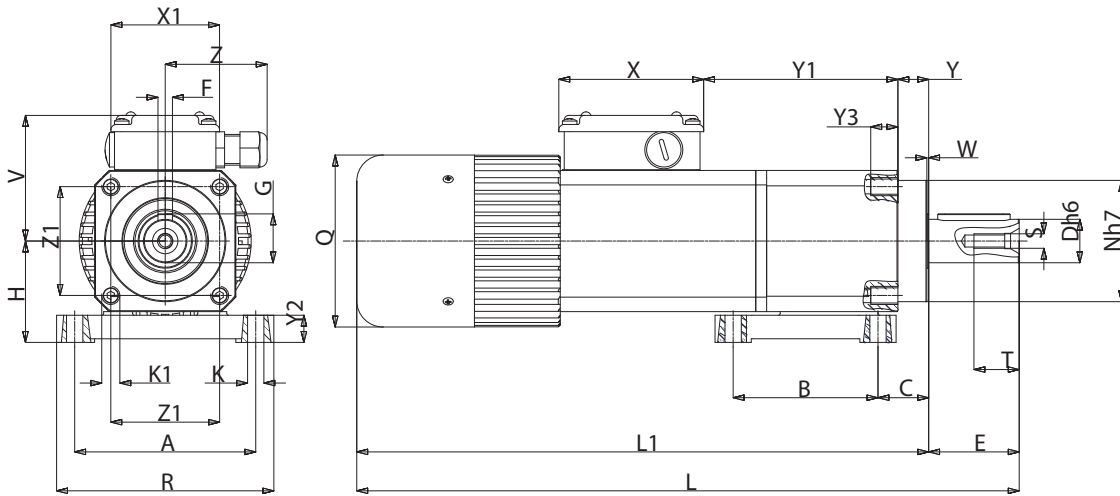

## B3

Type Tipo	A	B	C	D	E	F	G	H	K	K1	L	L1	N	Q
PAE...M2	3.937	3.149	1.102	0.944	1.968	0.314	1.062	2.204	0.354	M10	14.448	12.480	2.637	3.740
PAE...M3	3.937	3.149	1.102	0.944	1.968	0.314	1.062	2.204	0.354	M10	15.433	13.464	2.637	3.740

Type Tipo	R	S	T	V	X	X1	Y	Y1	Y2	Y3	W	Z	Z1	Weight Peso lbs
PAE...M2	4.724	M8	0.866	2.795	3.149	2.362	0.669	4.251	0.590	0.590	0.039	2.204	2.362	15.43
PAE...M3	4.724	M8	0.866	2.795	3.149	2.362	0.669	4.251	0.590	0.590	0.039	2.204	2.362	17.10



# PAE

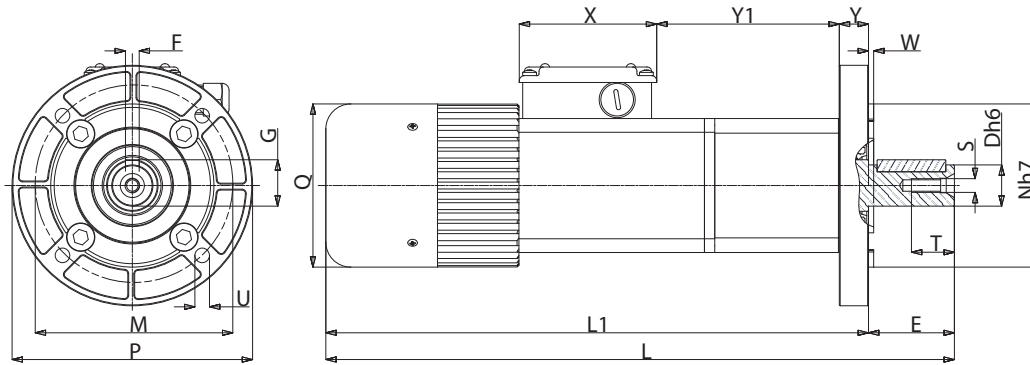

## B5

Type Tipo	D	E	F	G	L	L1	M	N	P
PAE...M2	0.944	1.968	0.314	1.062	14.448	12.480	4.527	3.740	5.511
PAE...M3	0.944	1.968	0.314	1.062	15.433	13.464	4.527	3.740	5.511

Type Tipo	Q	S	T	U	X	Y	Y1	W	Weight Peso lbs
PAE...M2	3.740	M8	0.866	0.354	3.149	0.669	4.251	0.118	15.43
PAE...M3	3.740	M8	0.866	0.354	3.149	0.669	4.251	0.118	17.13

For the self-braking version, add the letter KA or KB to the type designation. Dimensions L, L1, increase by 0.984 inch.

En la versión freno, añadir las letras KA ó KB a la sigla del tipo. Las cotas L, L1 aumentan de 0.984 inch.